

IMI PBM

Proven Clean Solutions for Personal Care

- BEAUTY & GROOMING
- COSMETICS AND PERFUME
- DEODORANTS
- DETERGENTS & FABRIC SOFTENERS
- HAIR CARE
- HOUSEHOLD CARE
- SHAVING CREAMS
- SKIN CARE & LOTIONS
- SOAPS & DYES
- TOOTHPASTE & ORAL CARE

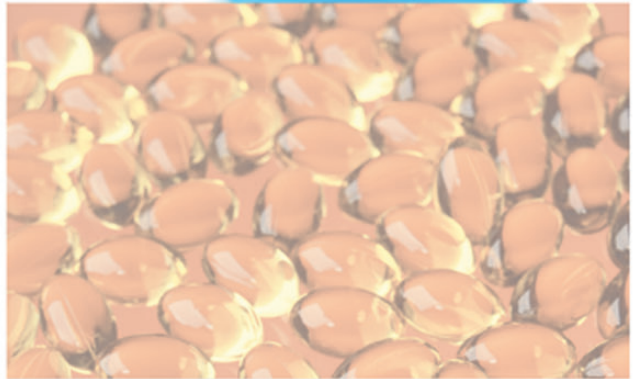

IMI PBM Custom Applications for Clean Processes

Space-Saving
Fabflex® Assemblies for
filling applications

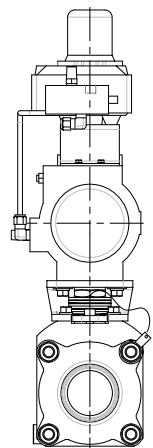
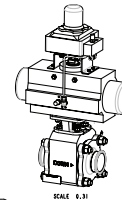
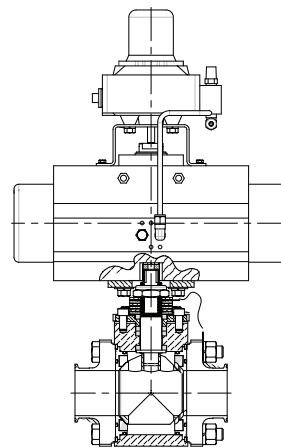
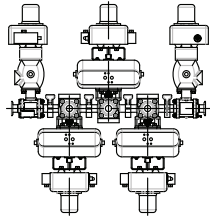
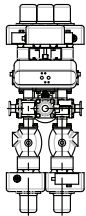
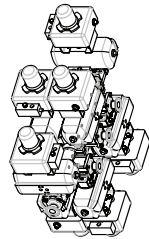
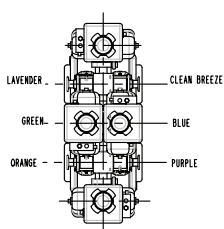
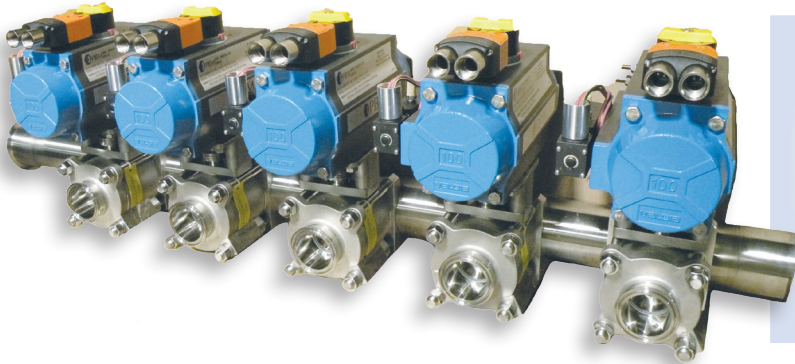
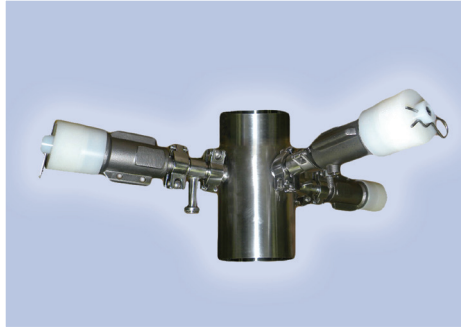

Fabflex® manifold of 8 automated valves
used for fragrance injection
Media: Liquid laundry detergent fragrances

Sanitary Igenix® fire-rated 2-way with
self-flushing ball
Media: Hand sanitizer

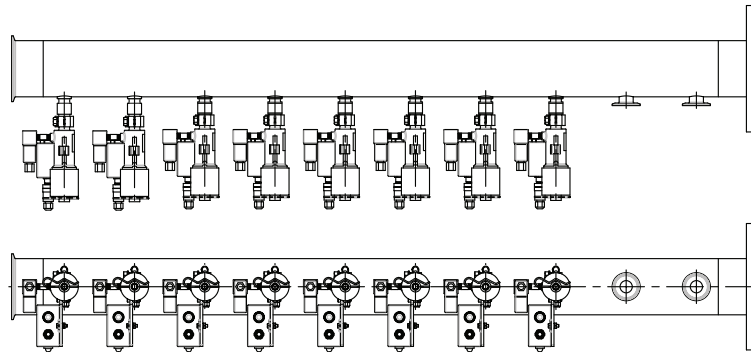

Fabflex® manifold with Rising Stem injector valves
Media: Fabric softener dye



IMI PBM



Cleanliness
Consistency
Reliability
Safety

Abrasion Resistance
In-line Cleanability
Quick Line Changeovers
Fire-Rated Option

For over 25 years, IMI PBM has listened to Personal Care industry requirements and delivered process improvements including cleanability, flow optimization and custom designs yielding positive impact on the total cost of ownership.

As an ISO 9001 valve design manufacturing company, IMI PBM provides the valve products and services required to minimize contamination, compliance with sanitary regulations, facilitate clean-in-place, solve clogging problems, process flammable additives, reduce downtime, and produce high quality cosmetics, fragrances, nutritionals, and other personal care products.

FEATURES

- Unique Adjust-O-Seal® design provides upstream sealing and in-line adjustment for seat wear
- Optional self-flushing ball completely cleans valve internals during line flush
- Unique up-stream sealing capability allows valve body cleaning, purging, draining
- True-Bore® (valve bore same as connecting tubing or pipe)
- USP Class VI elastomers and FDA complaint materials
- Available in variety of materials including 316L, Hastelloy™, AL6XN™, many others
- Variety of mechanical polish finishes as well as electropolish
- Optional unique fire-rated sanitary design isolates product media from graphite
- Full range of direct-mount automation and controls
- Optional Patented Locking Lever Handle
- High pressure valve options available
- Variety of end connections including extended tube or pipe weld ends, hygienic clamp, compression
- Certified Material Test Reports (CMTRS) provided for wetted components

Independent lab testing validating cleanability of IMI PBM's Self-Cleaning valves:



Engineering Report 41898-3

Valve Flushing Performance Test

for

PBM
1070 Sandy Hill Road
Irwin, PA 15642

Prepared by

Nora R. Somers

Nora R. Somers, Technical Writer

Dan R. Haag

Dan R. Haag, Hydro Test Technician

Approved by

John A. Benek

John A. Benek, Fluids Department Manager

This document shall not be reproduced except in full, without the written authorization of Environ Laboratories LLC.

8728 Grand Avenue South • Minneapolis, MN 55421
952-480-7750 • FAX: 952-480-4345 • 800-450-3710
www.environlab.com

Page 1 of 11

Igenix® Clean Valves for Clean Processes

Clean Solutions for Processing Cosmetics, Fragrances, Nutritionals
and Detergents

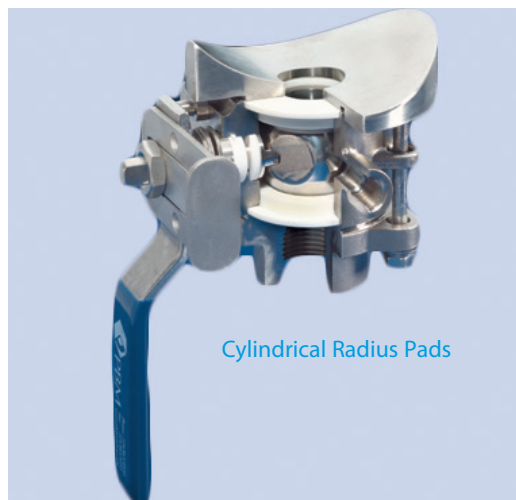
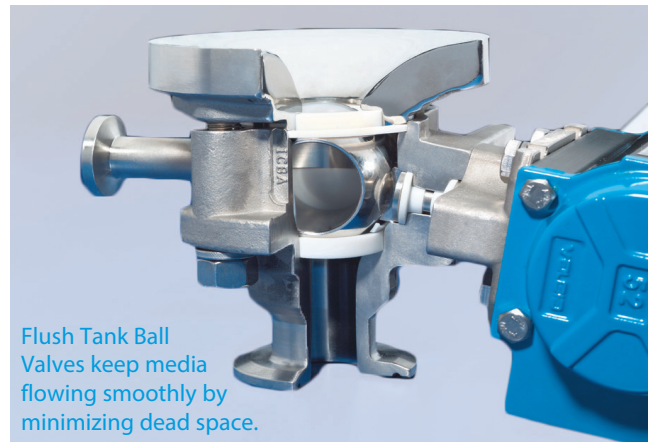

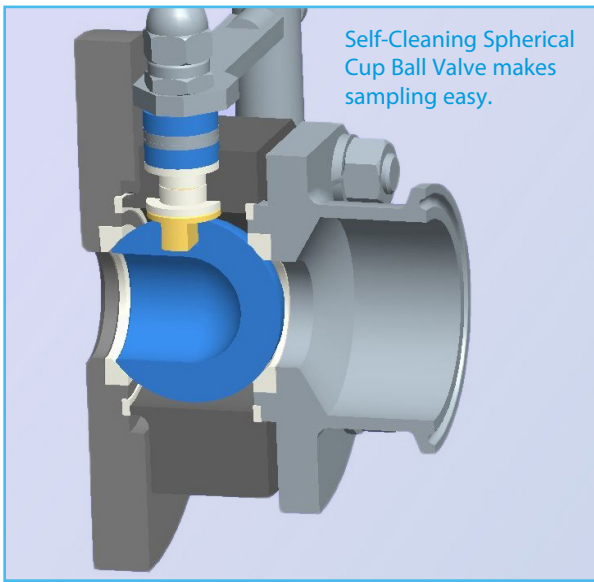

Self-Cleaning Spherical Cup Ball Valve makes sampling easy.

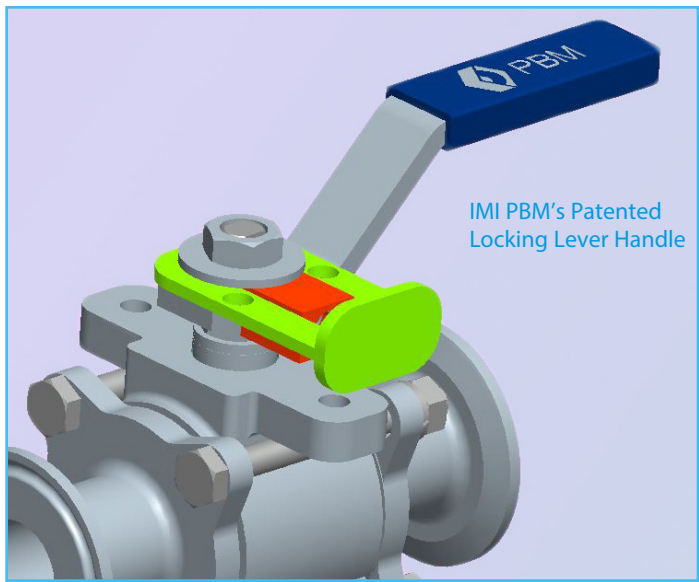

IMI PBM's Patented Locking Lever Handle

Z-Ball® (Zero Dead Leg) Ball Valve Design

View our YouTube video on the web!



120° Pigging Style Valve

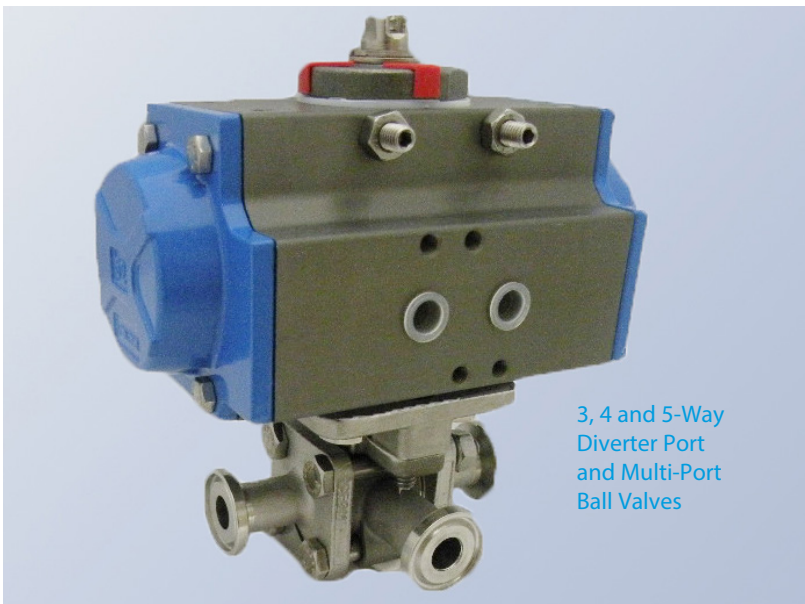

3, 4 and 5-Way Diverter Port and Multi-Port Ball Valves



Rising Stem Sampling valves

Standard Features Make IMI PBM Valves Perform

Adjust-O-Seal®

The exclusive IMI PBM Adjust-O-Seal design allows in-line adjustment to compensate for normal wear on seats. This reduces downtime, maintenance, and repair costs by increasing the time between seat replacements. The valve seats are always compressed against the ball. This keeps process media out of the body chamber surrounding the ball. The Adjust-O-Seal design is a standard feature on most IMI PBM ball valves.



Clean-In-Place Capability

Certain IMI PBM valves provide CIP capability in applications where material can become trapped in the body cavity or where it may be necessary to sanitize the valve with steam or a cleaning agent. These valves have a combination of purge ports and milled flats designed to suit specific application needs. The Adjust-O-Seal feature provides simultaneous upstream and downstream sealing – permitting CIP without process interruption. View our features videos on the web!

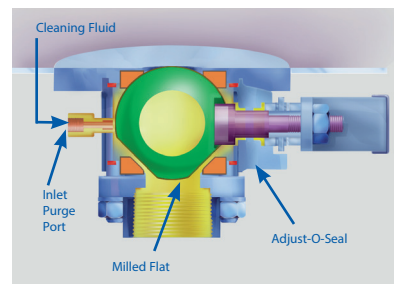

IMI PBM Automation Completes the Solution

IMI PBM offers a selection of pneumatic and electric actuation packages. Most IMI PBM valves are designed to accept Direct Mount Actuation that utilizes the valve stem as an integral part of the actuator drive. This design provides improved cycling life and performance, while reducing the total package profile. Direct Mount Actuation also eliminates the need for additional brackets or extensions. IMI PBM Direct Mount Actuation includes a stainless steel bracket and insert as standard. IMI PBM can easily mount a IMI PBM valve to any actuator with a female drive and an ISO bolt pattern.

- Electric and pneumatic
- Direct Mount
- Torque outputs of 25,000 in.-lb.
- Bi-directional Travel Adjustments
- Electric actuators can perform an almost limitless range of functions when equipped with optional features and related control equipment
- Pneumatic styles:
 - Rack & Pinion Double Acting
 - Rack & Pinion Spring Return
- Solenoid valves (NEMA 4, explosion proof, IS)
- Position monitors with mechanical or proximity switches
- Pneumatic and Electro-Pneumatic Positioners

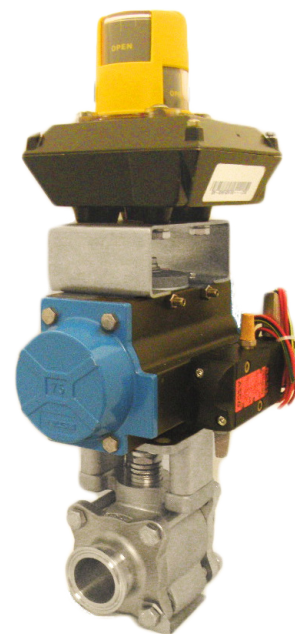

IMI PBM

1070 Sandy Hill Road,
Irwin, PA 15642 USA

Tel: +1 800 967 4PBM / 724 863 0550

Fax: +1 724 864 9255

info.pbmvalve@imi-critical.com

www.pbmvalve.com

IMI Critical Engineering

Lakeside, Solihull Parkway
Birmingham Business Park
Birmingham B37 7xz
United Kingdom

Tel: +44 (0)121 717 3700

Fax: +44 (0) 121 717 3701

imi-critical.com

