

Igenix® Series 6

Sanitary Fire Rated Ball Valve

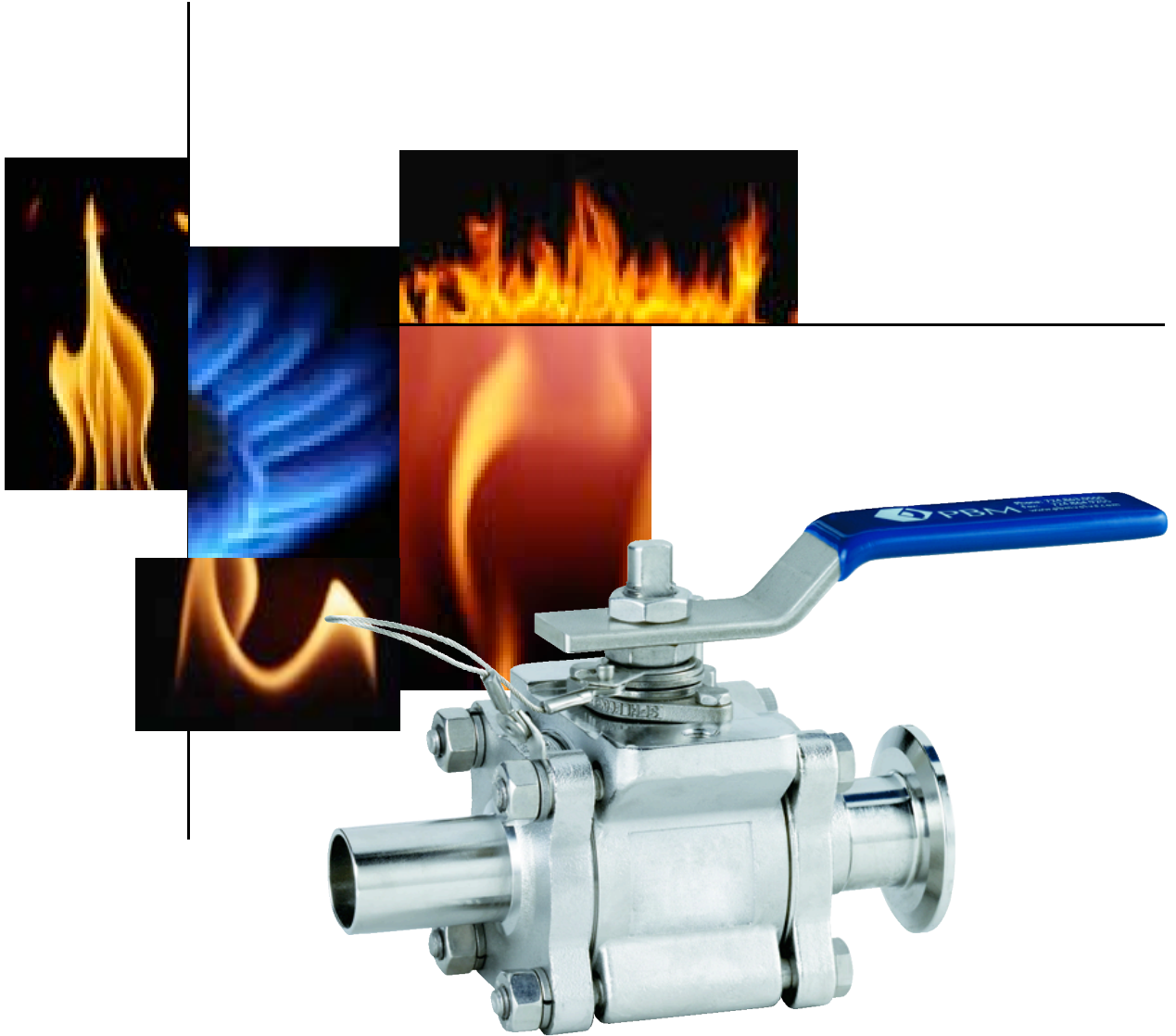

Sanitary Fire Rated Valves



PBM's Sanitary Fire Rated design valves accommodate flammable media in sanitary process environments.

FEATURES

- 1/2" through 3" sizes
- Passed API-607 Ed. 4 testing
- 2-way and Flush Tank Design
- 316L stainless (ASTM A351 CF3M) Hastelloy C276 and other ASME B16.34 listed materials.
- True Bore® port diameter same as tube ID
- Extended tube ends, compression ends, others available
- Spring return handle with fusible links
- Direct mount automation with fusible links and/or electro-thermal links

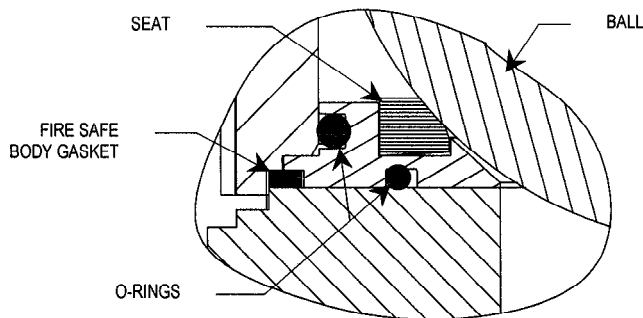

The API-607 qualified valves feature a backup metal seat against which the ball seals if the normal polytetrafluoroethylene seats melt under fire conditions. This metal seal allows only limited leakage under fire conditions.

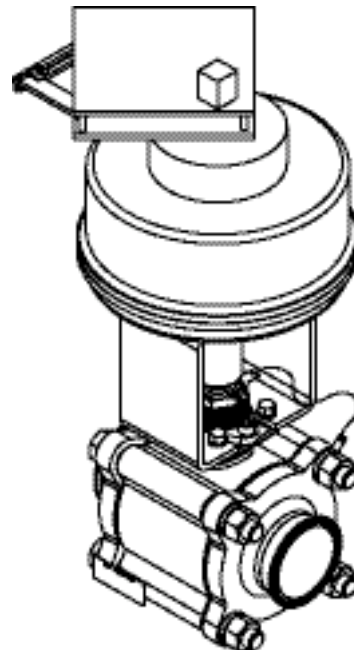

Sanitary Fire Rated Valve with manual fail safe spring return unit

MANUAL BALL VALVES

PBM's Igenix® Sanitary Series 6 ball valve is a three-piece True-Bore® design where the port Internal Diameter (ID) of the ball, seats and end connections are the same as the ID of the system tubing.

Seats and seals are FDA compliant TFM™ material. Body seals incorporate an FDA approved elastomer (USP Class VI on request) or encapsulated elastomer based on media compatibility. Stem packing is live-loaded white TFM. Graphite body gaskets and packing are isolated from the process media under normal conditions, and are exposed only in the event of elastomers melting under fire conditions. Valves are API 607 Edition 4 Qualified, designed with metal back-up seats which limit leakage in the event of a fire.

End fittings match the tubing connections. Orbital weld end fittings have a wall thickness to match connecting tubing and have a controlled sulfur content of .005% through .017%. The valves are static grounded, and do not require disassembly for welding.

Body bolts are fully encapsulated. Body bolts and nuts are A193/A194 Grade 8 stainless steel. I.D. and O.D. surface finish shall be the same as specified for tubing. Optional mechanical or electropolishing for internal and external finishes. Maximum working pressure is 720 psig and full vacuum.

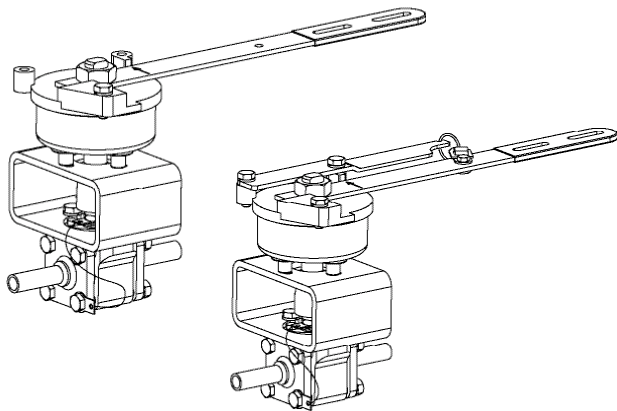
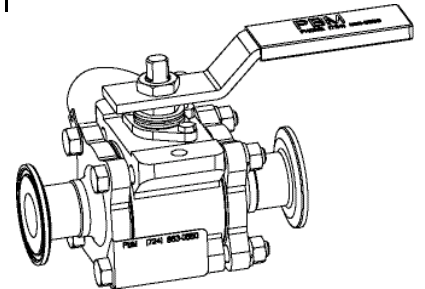
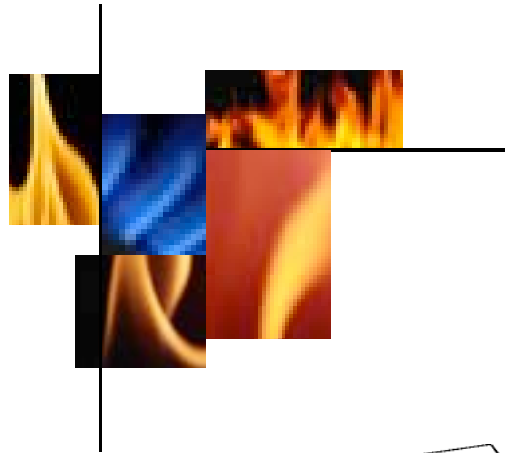

MANUAL BALL VALVES WITH SPRING RETURN HANDLE AND OPTIONAL FUSIBLE LINK

PBM's Igenix® Sanitary Series 6 Manual Valves can be modified with a bracket-mounted Spring Return Handle unit. The Spring Return Handle unit can be equipped with an optional fusible link specified to a customer's required melt temperature, which closes the valve during fire conditions.

AUTOMATED VALVES WITH SPRING RETURN DIRECT MOUNT ACTUATOR

PBM's Igenix® Sanitary Series 6 Manual Valves can also be modified with the addition of a "Direct Mount" spring return pneumatic actuator. The actuator — a double opposing piston, rack and pinion design with bi-directional pinion travel stops and hard anodized aluminum oxide body with co-deposited fluoropolymer—is sized utilizing a 100% safety factor. The mounting bracket is stainless steel, and the end caps are polyester powder coated with 300 series stainless steel fasteners. The valve stem inserts directly into the actuator drive adapter. These automated valves can be outfitted with fusible or electrothermal links which can allow the incorporation of valve safety into your process design automation system.

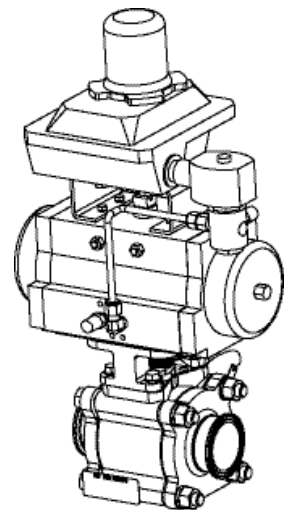



United States • Canada • United Kingdom • Mexico • South America • Europe • Australia • Taiwan

Visit PBM online at
www.pbmvalve.com
 to find the PBM domestic or international representative near you.

How to Order PBM Series 6 Sanitary Igenix® Fire Rated Valves

Product (1-2)		*Material (3-4)		Size (5)		Series (6)		*End Fittings (7-8)		**Seat/Filler/O-ring (9)		Options (10-11)		Ball/Stem (12)		***Operator (13-14)		Polish (15)	
SI	Sanitary 2-Way	HL	316L S/S	C	1/2"	6	Series 6 Fire Test	CT	Compression	G	TFM™/None/Viton	--	No options available	-	No option	--	Lever handle	A	20 R _a ID
				D	3/4"			F-	Ext. Weld Tube	J	TFM/VTFE/Viton	G	17-4 PH SS Stem	04	Locking handle	C	20 R _a ID / 32 Ra OD		
FI	Igenix® Sanitary Flush Tank	C-	Hastelloy C	E	1"			X-	Sanitary Clamp	Z	TFM/None/EPR					10	Manual Spring Return Handle	D	15 R _a ID
				G	1-1/2"			FX	Weld X Clamp	2	TFM/VTFE/EPR					E	10 R _a ID		
				H	2"			C	VTFE/None/Viton	11	Manual Spring Return Handle with fusible ink					F	20 R _a ID with EP		
				J	2-1/2"			D	VTFE/VTFE/Viton	G	15 R _a ID with EP								
		Y-	Hastelloy C-22	J	2-1/2"			T	VTFE/None/EPR	H	10 R _a ID with EP								
				K	3"			U	VTFE/VTFE/EPR	18	4" extended locking handle								
				7	VTFE/None/Encapsuled Viton			34	80 psig SR act.										
				8	RTFE/None/Encapsuled Viton			41	60 psig SR act.										

Notes:

- * Other ANSI B 16.34 materials and other end fittings available on request.
- ** Other encapsulated elastomers also available on request.
- *** For automated fusible and electrothermal links, consult factory.



PBM, Inc. 1070 Sandy Hill Road • Irwin, PA 15642
 (800) 967-4PBM • (724) 863-0550 • Fax: (724) 864-9255
 E-mail: info@pbmvalve.com • www.pbmvalve.com

